



landscapeforms

Typology Collection

Sky & Earth / Light & Shadow: Uniquely Immersive Outdoor Experiences

The Typology Collection is an innovative seating and lighting system that adds dynamic new dimension to any site, enveloping the visitor—both from above and below—in an immersive experience. Sculptural elements play in both the vertical and horizontal planes, incorporating both light and shadow, to draw the eyes skyward then back to the earth with signature design features.

The collection is systemic and adaptable, living comfortably in both new and existing architectural environments to guide the movement of traffic and create unique, three-dimensional spaces that invite and connect, surprise and inspire. The materials are elegant and refined, yet resilient and enduring—cast aluminum and concrete run as a common thread through the collection to create a unified visual and tactile experience. Technological advances in manufacturing and lighting integration challenge preconceptions of form and space.

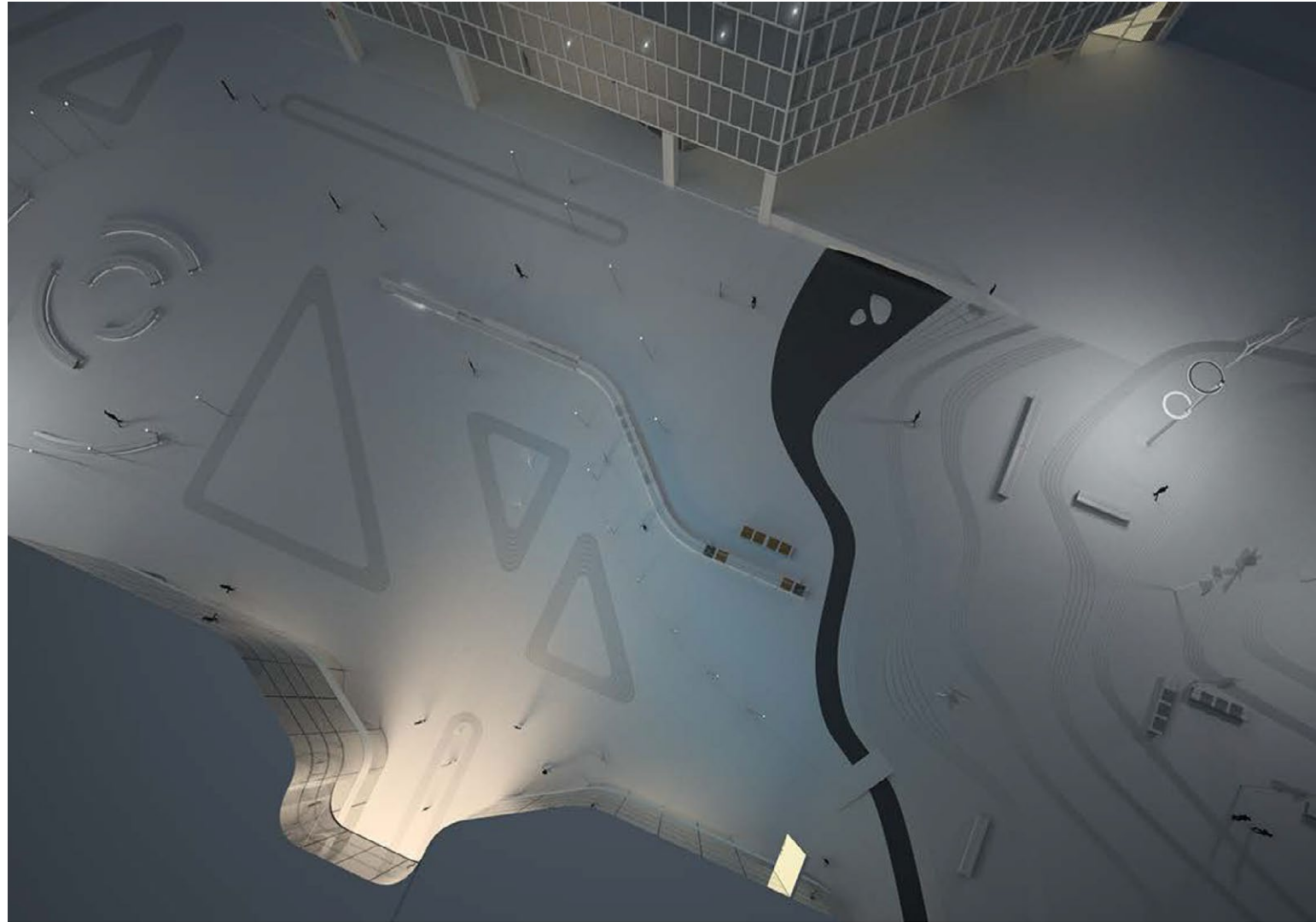



DESIGN WORKS

A BMW Group Company

A Collaboration Between Award-Winning Design Leaders

To create the Typology Collection, Landscape Forms collaborated with Designworks, the innovation studio for the BMW Group, a global creative consultancy and an international leader in product development and industrial design. Drawing on insights from the future of urban landscapes, mobility demands of the new public space, and global workplace and transportation cultures, the collaboration leverages the award-winning teams' complementary expertise in product innovation, artful design, and state-of-the-art manufacturing.







Unique Yet Unified

Complementary yet distinct elements bridge the realms of the sky and the ground to create a magnetic and immersive user experience. Each piece has unique and memorable design features, but the overall sculptural quality and the artistic use of lighting within each component enable the collection to make a larger, unified statement. Each component alone could be the centerpiece of a site, but when working in concert, the Typology Collection creates an extraordinary environment.

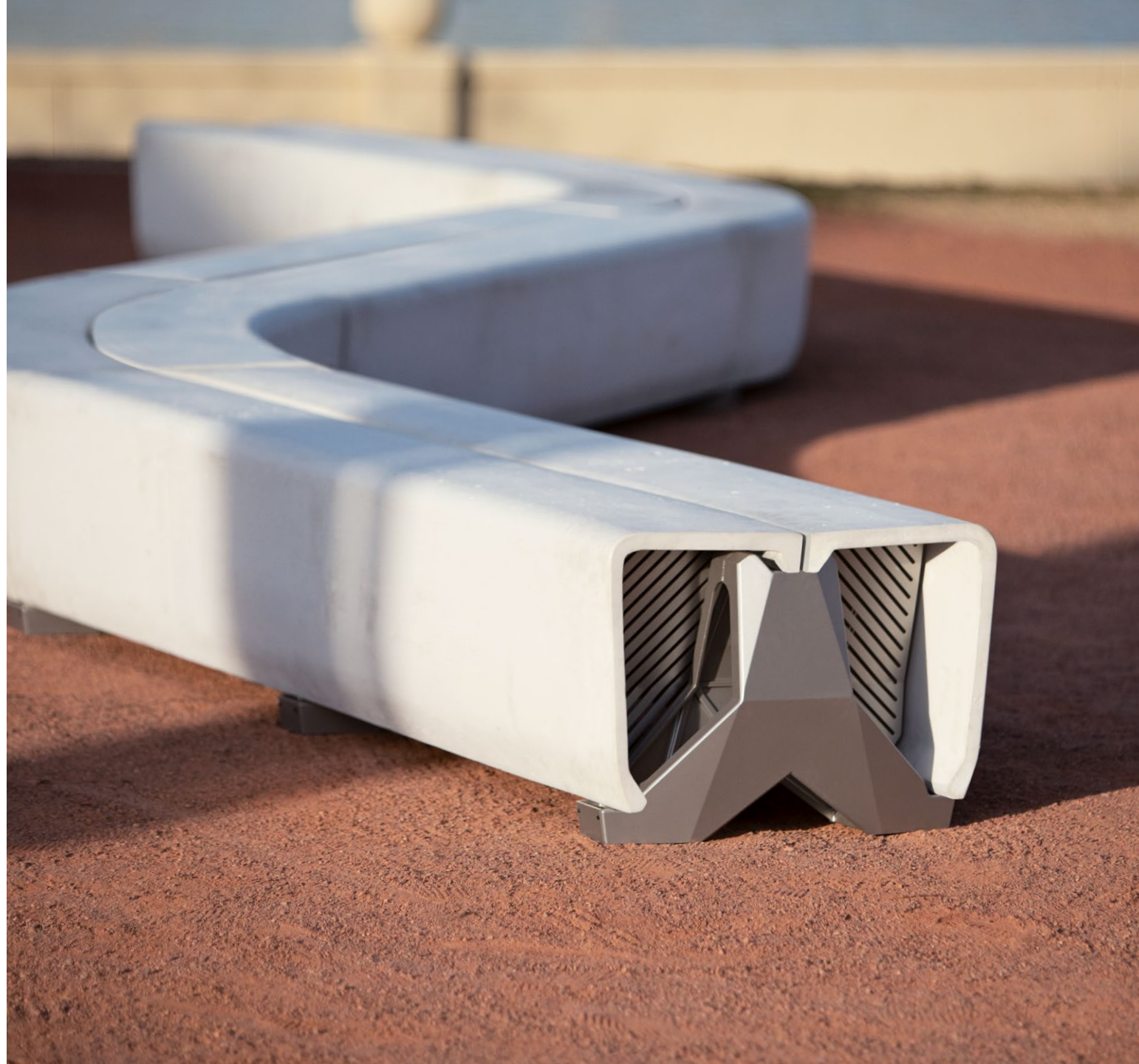

Space Within Space

As the Typology Collection meanders through city spaces—symmetrically sinusoidal or organically serpentine in contrast to the urban array—it can suddenly transform into focal points of community interaction. Concentric circular or arced configurations invite people to rest, repose and connect with others sharing the space, a counterpoint to the anonymity of a bustling urban environment. It transcends the boundaries of two-dimensionality in its floor plan, creating new inviting and encompassing three-dimensional spaces within the larger context of its surroundings.



Light and Shadow

The Typology Collection presents illumination in a way that is uniquely artful and imaginative. During the day, the striking form of the luminaires adds visual interest to the space, and at night, the way the light is cast is art in and of itself. Seating elements with integral lighting seemingly float throughout the landscape, contrasting light from above and illuminating the ground below. Innovative lighting solutions create installations that are chiefly functional yet also surprise, delight and enhance the landscape even when not in use.



Adaptable Systemic Design

The Typology Collection complements virtually any space in a meaningful, aesthetic and practical way. Modular components respond to existing architecture and allow for reciprocity with complex streetscapes—guiding people through passing spaces and bridging interconnected hubs of activity. The Typology Collection is expandable to support future changes and developments to the urban landscape.



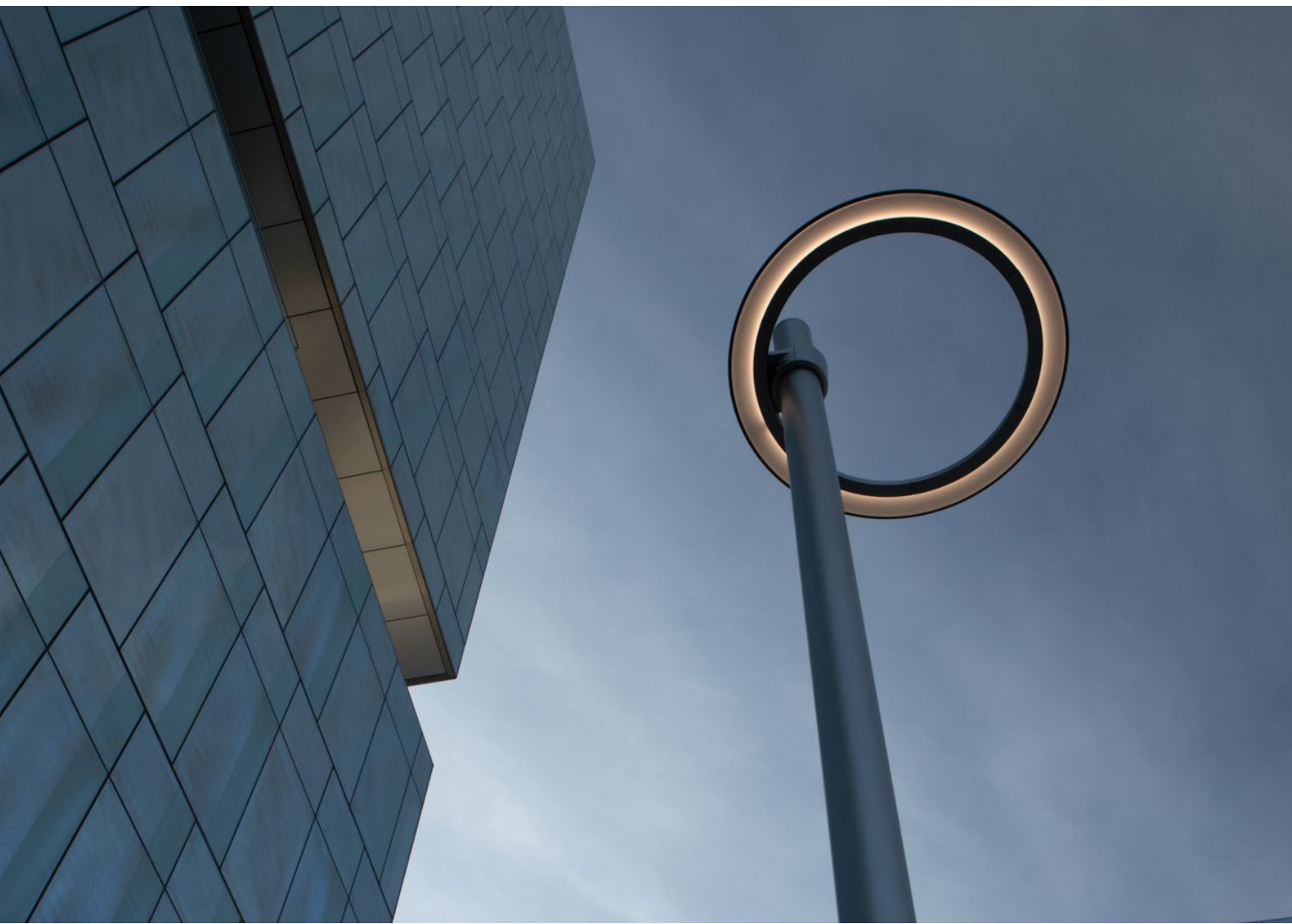





Typology's Elements

A Meandering Stream

The **ribbon bench** is the centerpiece of the Typology Collection. Modular segments in a straight configuration and two different degrees of small and large radius enable the bench to meander seamlessly throughout the landscape. It defines spaces, connects spaces, guides pedestrians, and can even form amphitheater-like circular or semicircular hubs that encourage community interaction.

On each modular segment, glass fiber reinforced concrete (GFRC) drapes like a mantle over cast aluminum supports to express an elegance, refinement and seemingly impossible lightness. Soft, rounded edges invite comfort and relaxation. Contrasting the smooth, radiused form of the concrete profiles, the cast aluminum feet and end caps—with faceted surfaces like cut gems—communicate heft, angularity and precision in manufacturing.

The central gap between the two concrete profiles serves as a mounting point for optional backrests, armrests and extended functional surfaces to be implemented in strategic locations throughout the configuration. Emanating from within the ribbon bench, integral downward-facing lighting illuminates the space around the feature, creating an illusion that the entire structure almost levitates.



A Looking Glass to the Sky

With illumination reminiscent of the sun's corona during an eclipse, **ring lights** are stunning, seemingly levitating light fixtures recognized instantly from almost a mile away. Perched atop a steel mast, a circular strip of LEDs creates a solid ring of ambient light that, when viewed from underneath, is like a looking glass to the sky. Ring Lights are striking pieces of industrial design by day, and by night, are enchanting and ethereal pieces of luminescent art.



An Illuminated Beacon

Stick lights break from lighting tradition such that the pole itself is one solid source of light. These vertical columns of warm white light stake claim to the site, accompanying the ribbon bench across its diverse configurations, and creating prominent visual landmarks that draw people in to the site. Arranged side-by-side, stick lights can divide spaces, punctuate spaces or create virtual rooms of light.





The Typology Collection opens a new realm of possibility in the way that the urban landscape is experienced. Immersive, sculptural elements bridge the vertical and horizontal realms, playing with light and shadow to draw the eyes skyward then back to the earth. Intelligent, systemic engineering complements existing architecture in meaningful and practical ways—defining and connecting spaces, and intuitively guiding the movement of visitors in and among them.





Materials

Vivid Series - Powdercoated Metal (Fine Texture)



Clay

Lemon

Mango

Chili

Loll Apple Red

Loll Leaf Green



Moss

Forest

Loll Navy Blue

Neutral Series - Powdercoated Metal



Silver Metallic

Mercury Metallic

Steel Metallic

Bronze Metallic

Titanium Metallic



Gloss Black

Gloss White

Architectural Series - Powdercoated Metal (Fine Texture)



Fog

Obsidian

Matte Black

Terra

Nutmeg

Onyx



Sage

Blue Ash

Dusk

Materials (cont.)

Glass Fiber Reinforced Concrete (GFRC)



Natural White

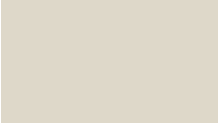

Natural Ecu



Natural Grey

Statement of Line

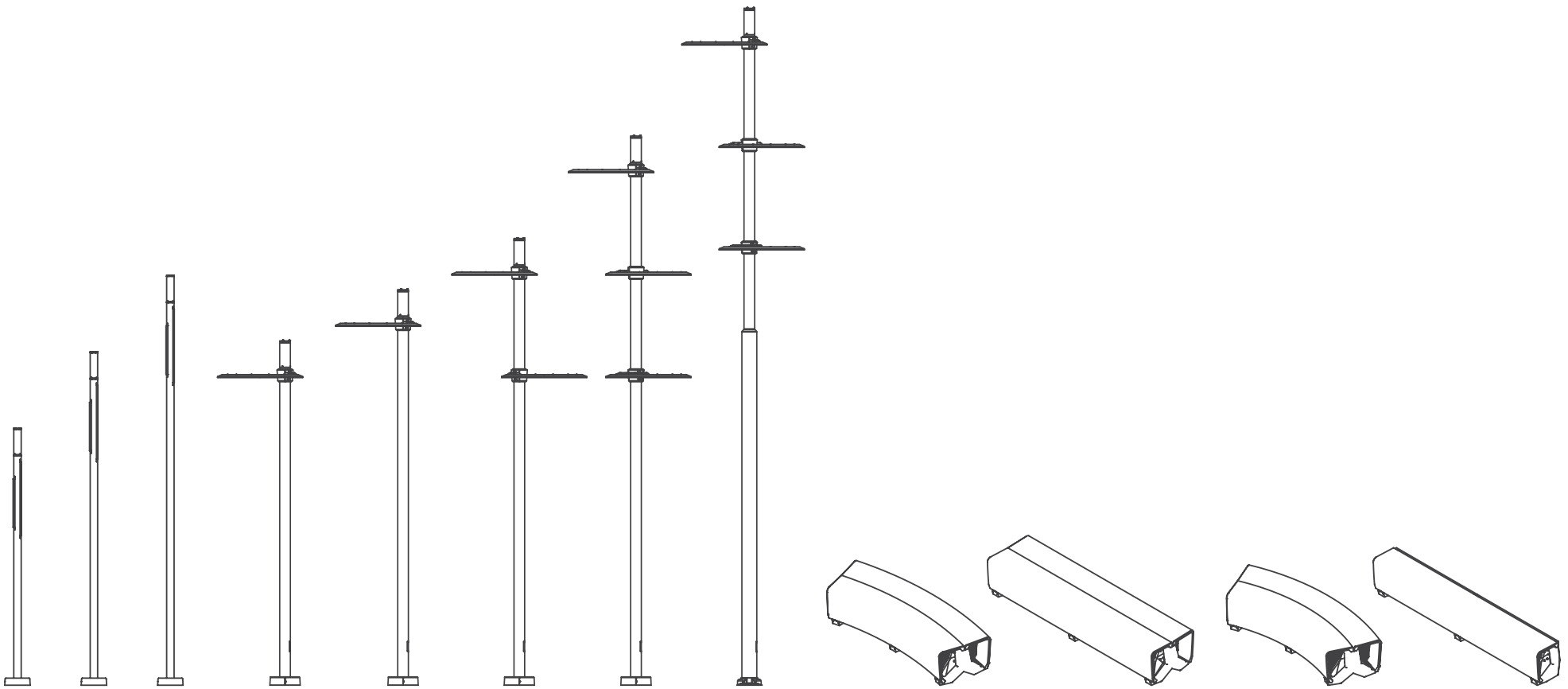

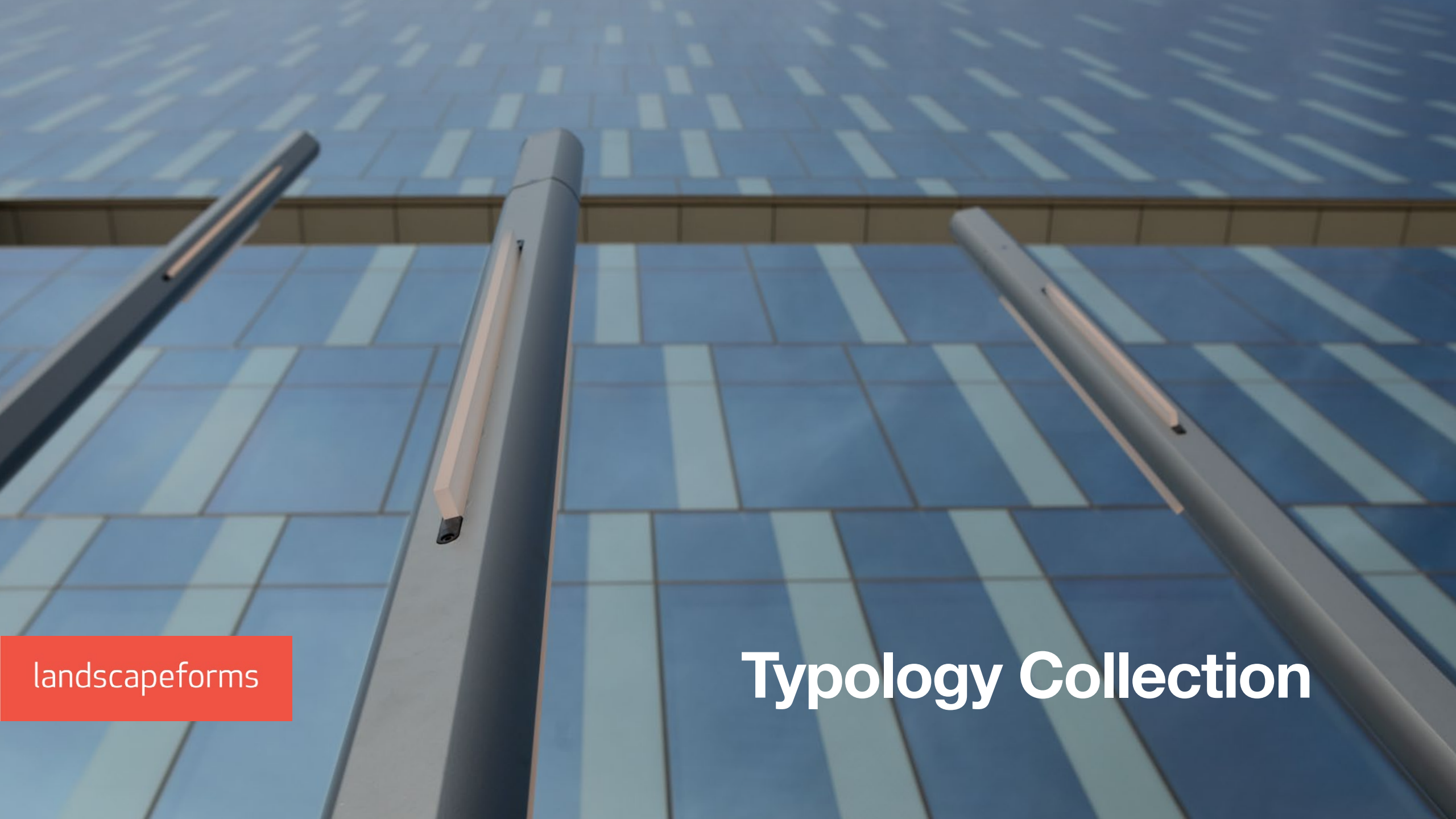

landscapeforms

Typology Collection