



landscapeforms

**Moment**



## **A minimalist approach inspires brilliant illumination.**

Informed by the interplay of impeccable lines, perfect circles and conical forms, the pure geometry of Moment finds expression in sculptural luminaires that are at once artful and practical, elegant and elemental. Moment presents a modern and unadorned profile that seamlessly complements any architectural environment with quiet subtlety and grace.

Created in collaboration with the Spanish design studio Yonoh, the bold essentialism and utilitarian simplicity of Moment celebrates the power of restraint, enhancing the vitality of the spaces they illuminate. Whether illuminating the sweep of a public square or lighting a landscaped path, the Moment line was designed to define and capture every step along the way. With a range of variable and scalable options, Moment adds elevated style to maximized performance, enhancing projects of any size and scope.

## Collaborative design.

Yonoh Creative Studio enjoys an international following as one of the most distinguished and celebrated names in the design world. Founded in 2006 by industrial designers Clara del Portillo and Alex Selma, and based in Valencia, Spain, Yonoh is renowned for their commitment to elevating form to its idealized function, bringing a fresh perspective and meticulous attention to detail to every project.

With a string of prestigious international awards to their credit and a portfolio that spans residential, commercial, and product design, Yonoh blends contemporary aesthetics with functional artistry to create objects and environments that thrill, inspire, and captivate audiences worldwide.





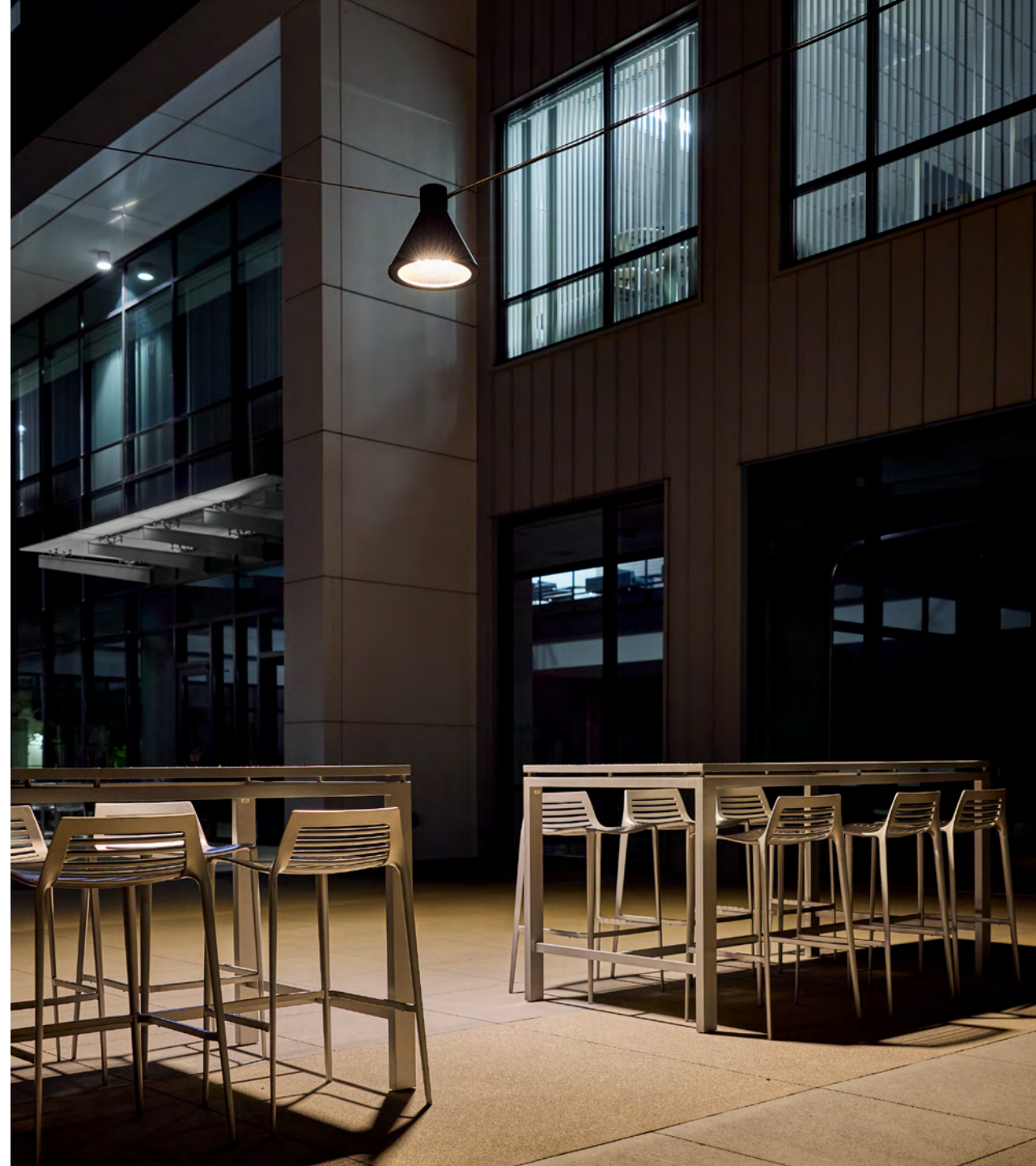

## Simplicity in objective & execution.

Moment exudes confidence without pretense. The incorporation of basic forms into its design motif creates a sense of order and symmetry. Careful attention has been paid to hide fasteners and extraneous transitions in its assembly, achieving a harmonious balance from base to pole, arm to luminaire. The beauty of Moment resides in its simplicity. Anything not essential to its function has been stripped away. Only the most essential elements remain.

---

### Minimalist design vocabulary

Extraneous transitions and fasteners removed from assembly

Clamshell base cover and nut covers available

No visible fasteners impede the symmetry of the luminaire face

Identical cylindrical arm treatment for both pole and wall-mounted configurations







## Designed for every environment.

Moment differentiates itself with versatile and highly adaptable solutions that integrate with any environment. The collection presents a simplified modern aesthetic that carries through an array of pole height and mounting configurations, including single, back to back, or staggered and spiral for accent and area lighting, in addition to catenary and wall-mounted configurations.

The multi-head high output configuration at 25 feet provides ample illumination to roadways and crosswalks, while a single luminaire at 12 feet softly illuminates a pedestrian path. In wall mounted scenarios, Moment's minimalist profile serves to complement both contemporary and historical architecture. While the pleasant geometry of the luminaire on catenary wire adds vibrancy to walkways, passthroughs, and building alleys, transforming them into amplifiers and catalysts of the urban experience.

---

GFCI optional

Occupancy sensor optional

Pole top-mounted twist lock optional

Lens heights at 12, 14, 16, 20 & 25 feet

Single, back to back, staggered and spiral polemount configurations

Up to 50 degree tilt in 10 degree increments and infinite rotation









## A brighter way forward.

Beneath the streamlined beauty of Moment, innovative lighting technology is at work. Distribution, color temperature and output are all available in multiple configurations. Moment's deep-set light engine prevents unwanted spillage with a natural shielding effect (accent distributions), while subtle exterior and underside air gaps ingeniously provide passive cooling around the cartridge.

For accent lighting, the hexcell louvre option further minimizes glare and limits visibility of the light engine from most points of observation. Balancing superb performance and visual comfort attributes with a minimalist aesthetic has enabled Moment to bring elevated solutions to any outdoor environment.

---

Color temperature options - 2700K, 3000K, 4000K

Lens types - frosted or clear

No tilt adjustment for area lighting applications (Dark Sky compliance)

Tilt adjustable luminaire for accent lighting

360° Rotational adjustment (all versions)

Passive cooling flow-through design

Deep-set light engine for inherent shielding/cutoff (accent lighting configuration)

Hexcell louvre option



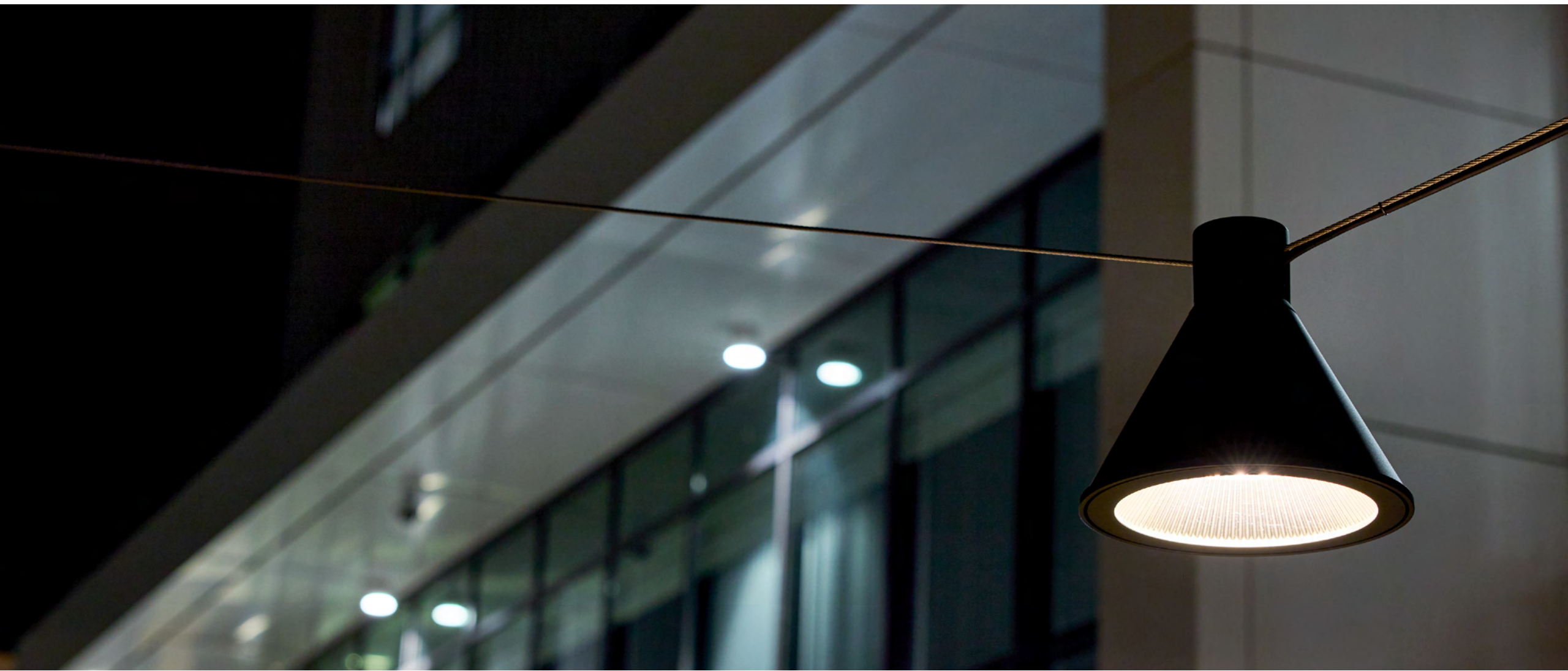



## Made to do more.

The achievement of Moment is the result of a fruitful design collaboration and partnership between Yonoh Studio and Landscape Forms. The beauty of this product reflects countless difficult decisions made in shared commitment to exacting design principles.

Moment is proudly made in Kalamazoo, Michigan (BA and BABA options available - contact factory).

---

Crisp, quality castings in Aluminum and Stainless Steel

Light cartridges are factory sealed and field replaceable

International DarkSky approved

3G Vibration rated for bridge lighting applications









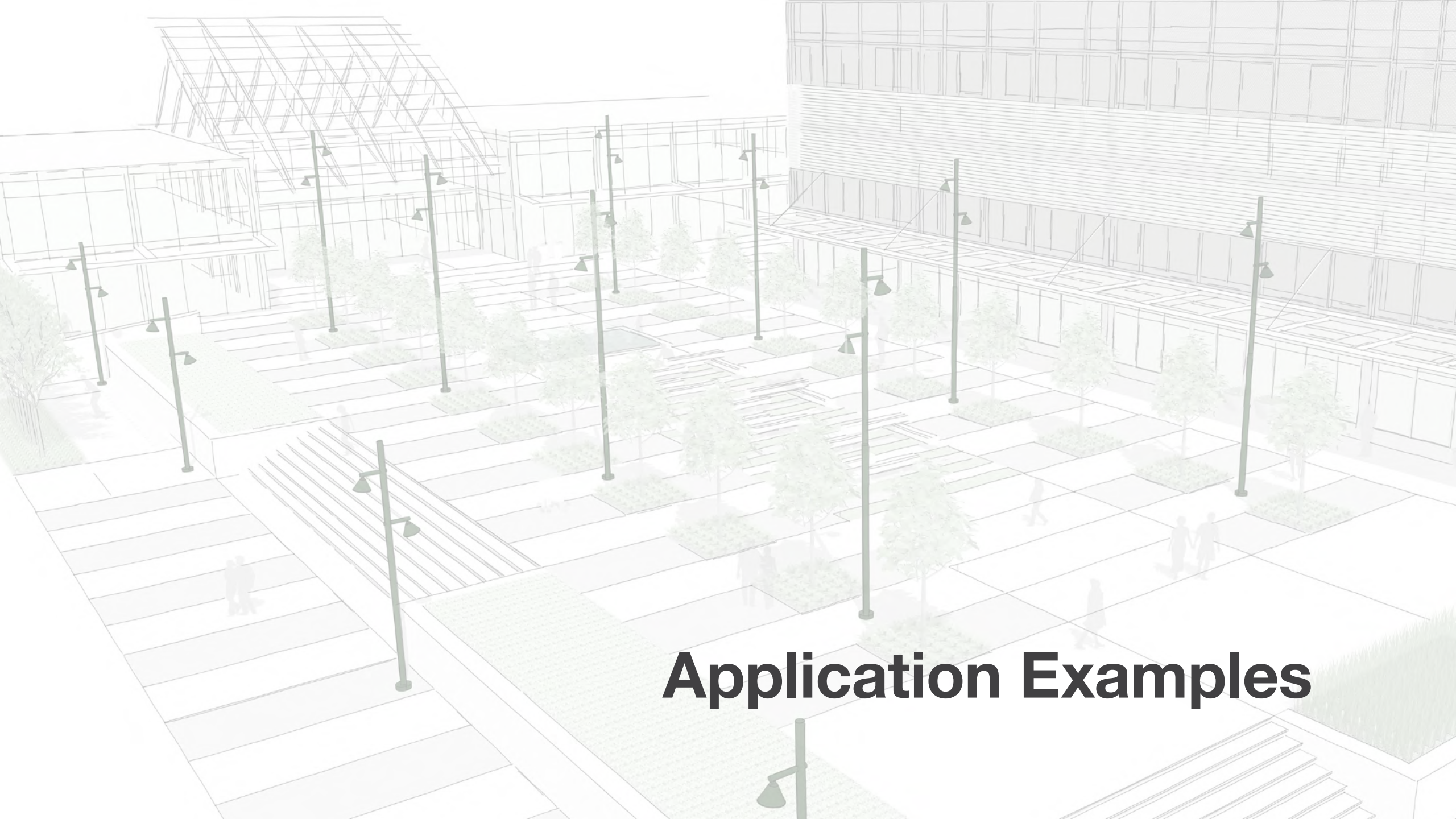

# Application Examples

Urban Park

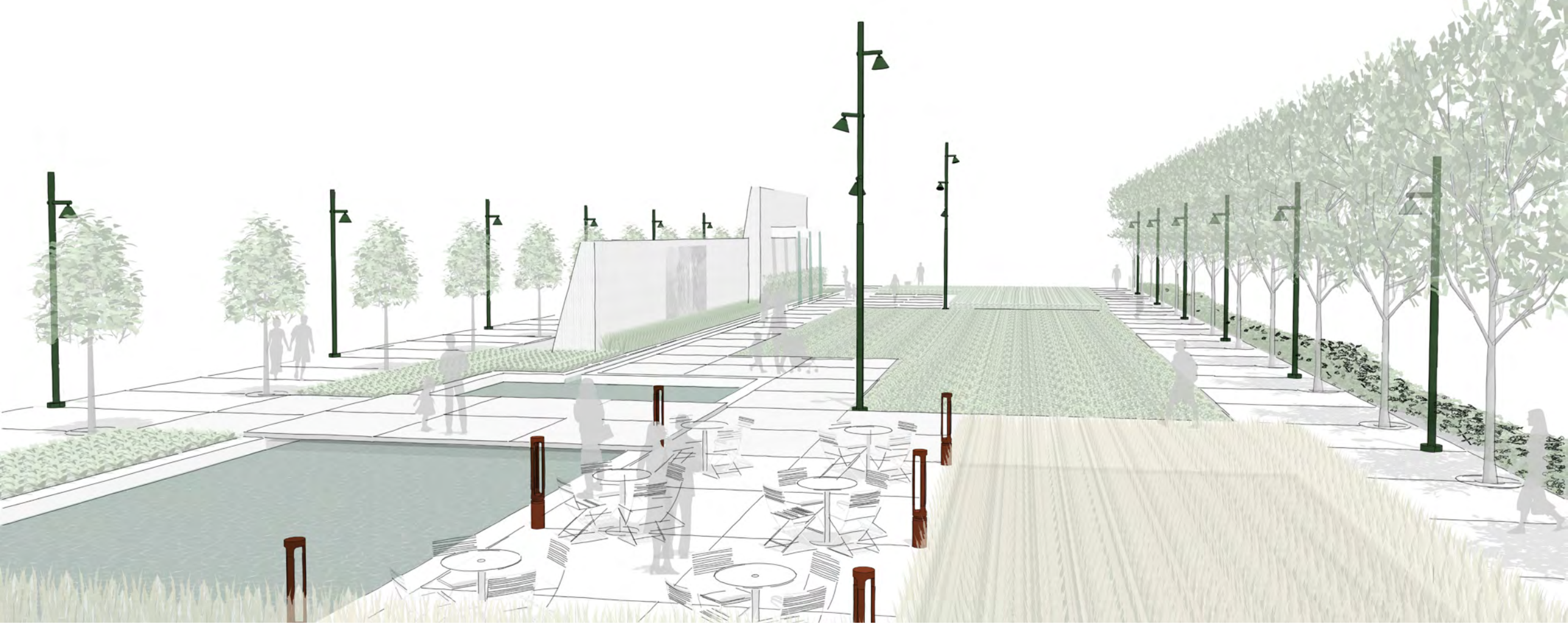

Urban Park

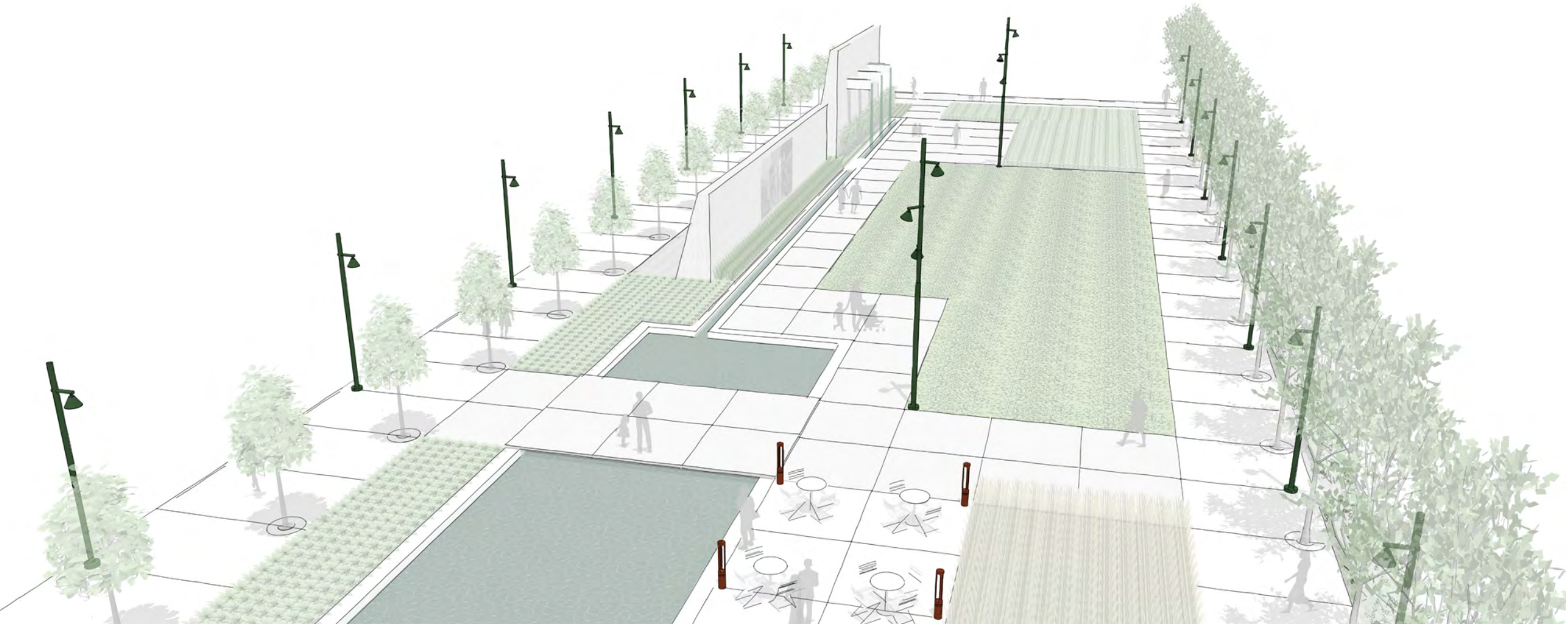

# Urban Park

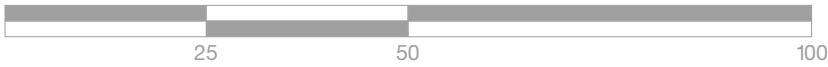
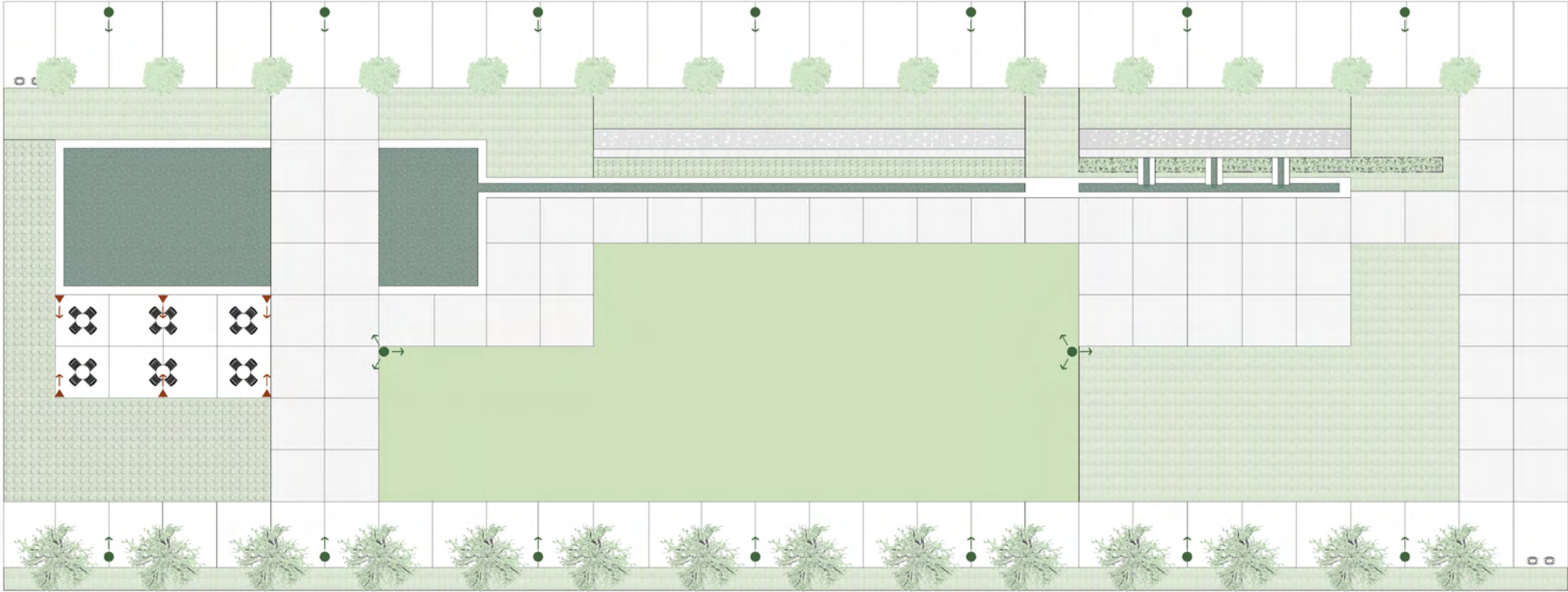

- Key**
- 4' Outline Bollard ▶→
  - 14' Moment Accent - Single head pole (DZ201 + DZP-14-A) ●→
  - 25' Moment Accent - 3 head Spiral (DZ201 + DZP-25C) ⊙→

**Transit Hub/Mixed Use Plaza**

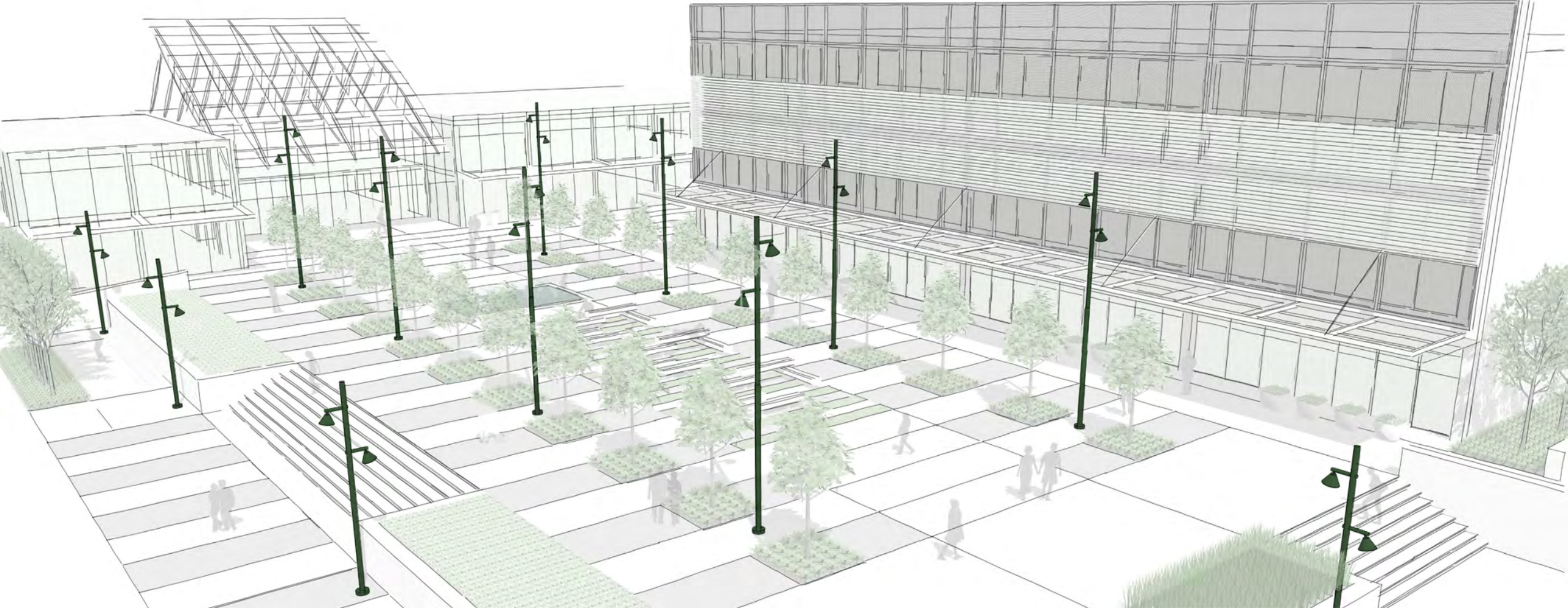

**Transit Hub/Mixed Use Plaza**

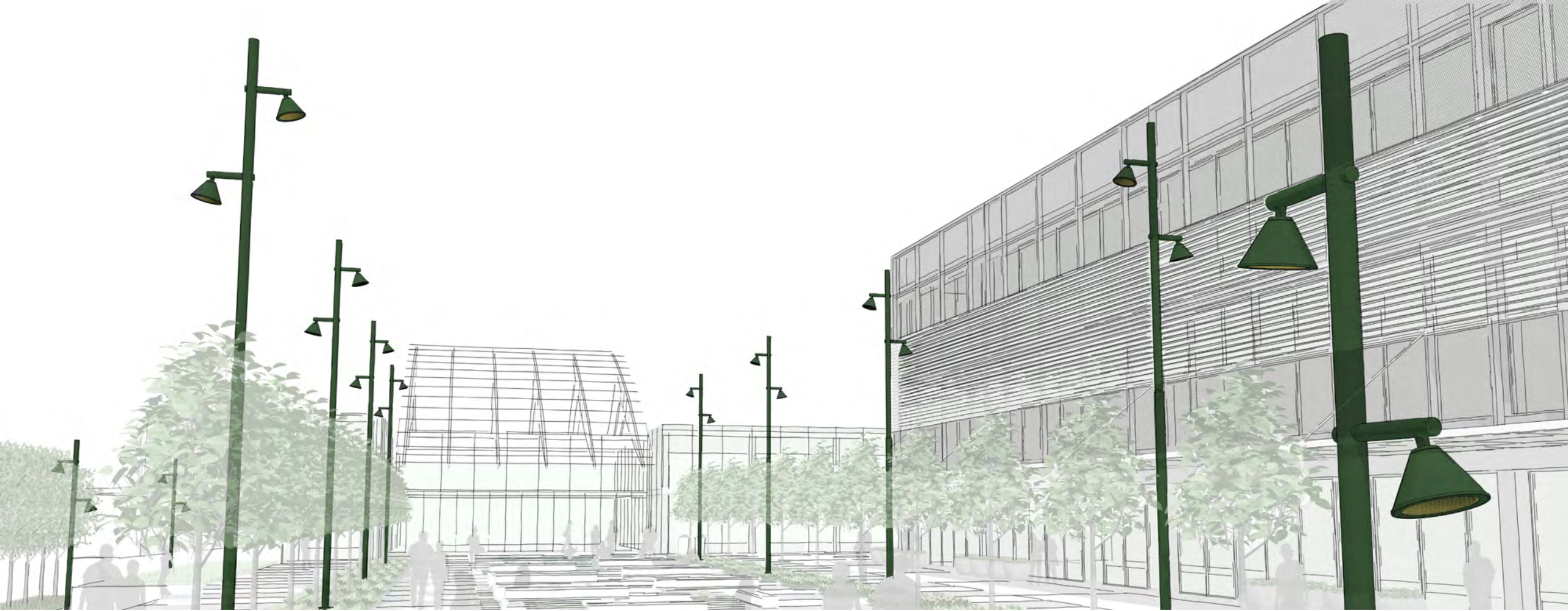

# Transit Hub/Mixed Use Plaza

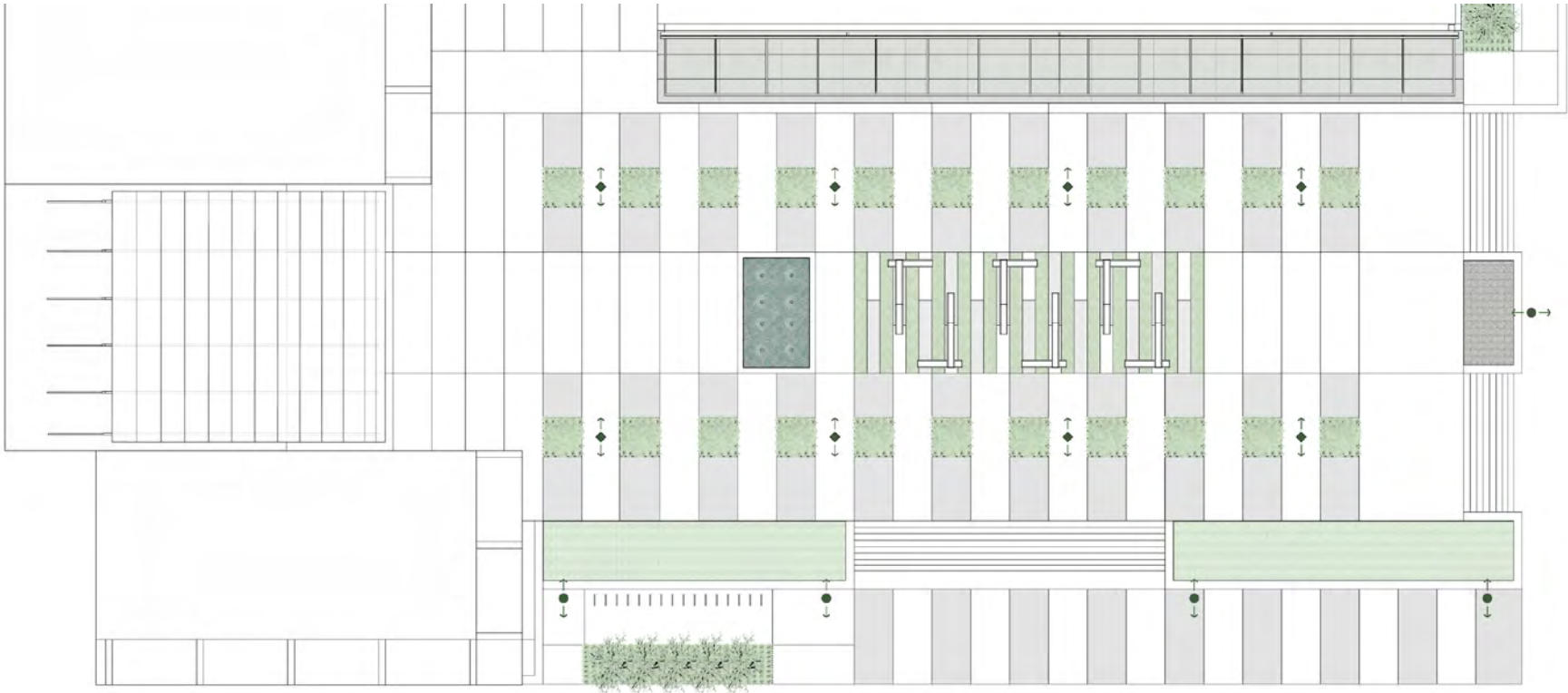

### Key

- 20' Moment Accent - Dual head, staggered (DZ201 + DZP-20-B) ←◆→
- 16' Moment Accent - Dual head, staggered (DZ201 + DZP-16-B) ←●→

**Pedestrian Mall**

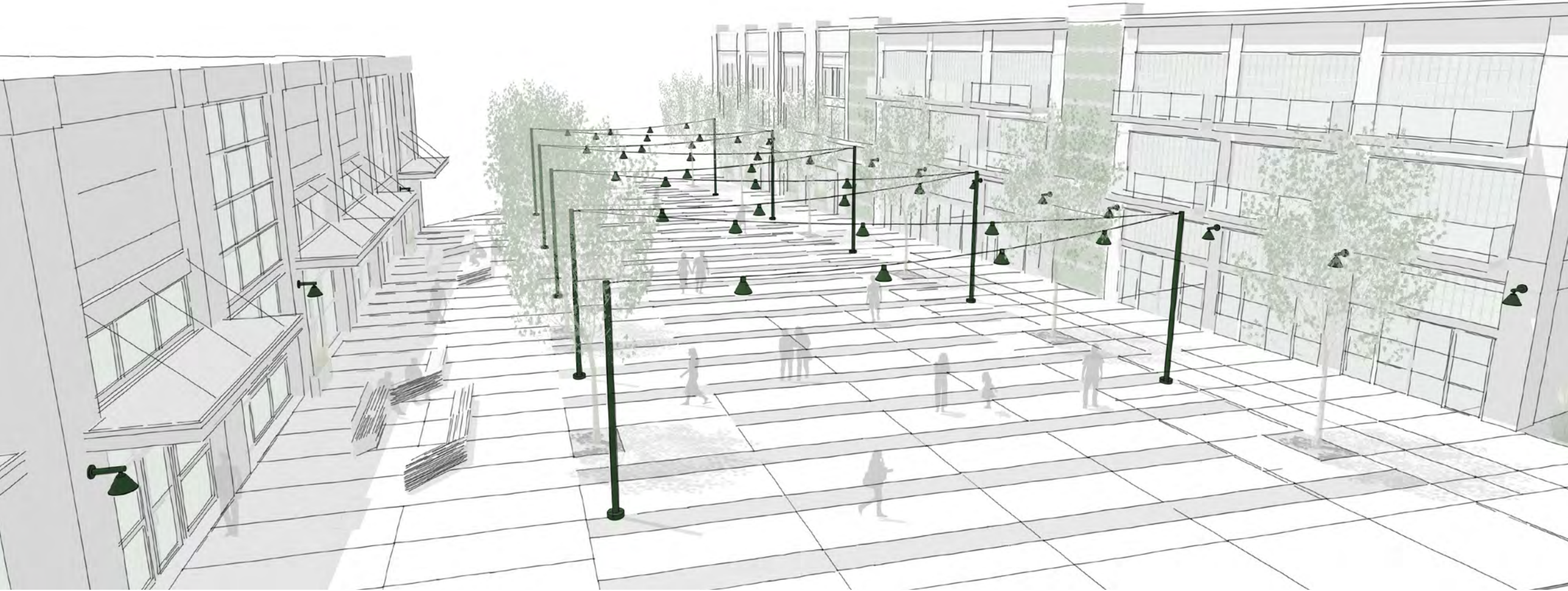



**Pedestrian Mall**

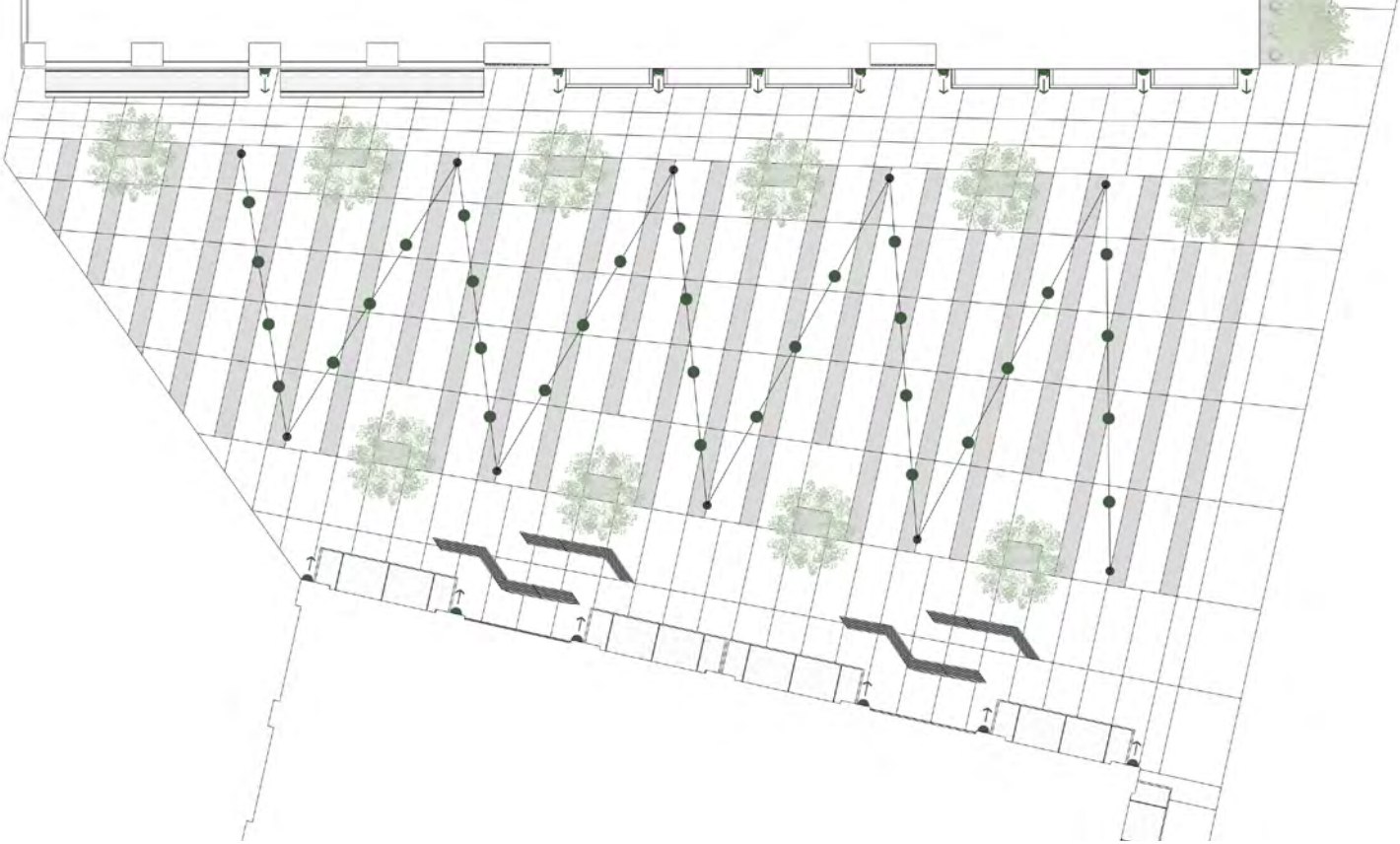

# Pedestrian Mall



- Key**
- Moment Accent - Wall Mount (DZ601) 
  - Moment Accent - Catenary at 12' lens height (DZ401) 

**Streetscape**





Streetscape



# Streetscape



- Key**
- Moment Accent - Wall Mount (DZ601) 
  - 12' Moment Roadway - Single head pole (DZ101 + DZP-14-A) 

# Materials

## Vivid Series - Powdercoated Metal\* (Fine Texture)



Clay

Lemon

Mango

Chili

Loll Apple Red

Loll Leaf Green



Moss

Forest

Loll Navy Blue

---

## Neutral Series - Powdercoated Metal\*



Silver Metallic

Mercury Metallic

Steel Metallic

Bronze Metallic

Titanium Metallic

Gloss Black



Gloss White

---

## Architectural Series - Powdercoated Metal\* (Fine Texture)



Fog

Obsidian

Matte Black

Terra

Nutmeg

Onyx



Sage

Blue Ash

Dusk

## Features

- Timeless, architectural, elegant design
- Engineered with visual comfort options for pedestrian-centric spaces
- Pole, wall, and catenary mounting options
- Full suite and area/roadway and accent distribution options within one form factor
- IDA Dark Sky compliant
- Tilt adjustment in 10° increments up to 50° (accent distributions only)
- 360° rotational adjustment (all versions)
- No visible fasteners on the front face
- Light cartridge – factory sealed and field replaceable
- Cast aluminum and cast stainless steel construction
- Catenary mount plumb with up to 12° line sag
- 3G vibration rated
- TM21 L70: >60,000hrs
- IP66 Rating
- 6-year warranty
- Made in Kalamazoo, Michigan  
(BA and BABA options available - contact factory)

## Options

- Lumen output 2,200 – 10,000lm
- 2700K, 3000K, 4000K (>80CRI min)
- 30 LED or 50 LED light engine
- Type I, II, III, IV, V  
Spot (20°), Medium (25°), Flood (45°)  
and Wide Flood (75°)
- SO or HO drive current options
- Clear or frosted lens
- Hexcell louvre (accent distributions only)
- 12', 14', 16', 20', 25' lens height options  
(pole mounted)
- 0-10V dimmable
- GFCI outlet with 'in use' cover
- PIR occupancy sensor (pole mounted)
- 7-pin NEMA receptacle (pole mounted)
- 2-piece cast aluminum base cover



# Statement of Line

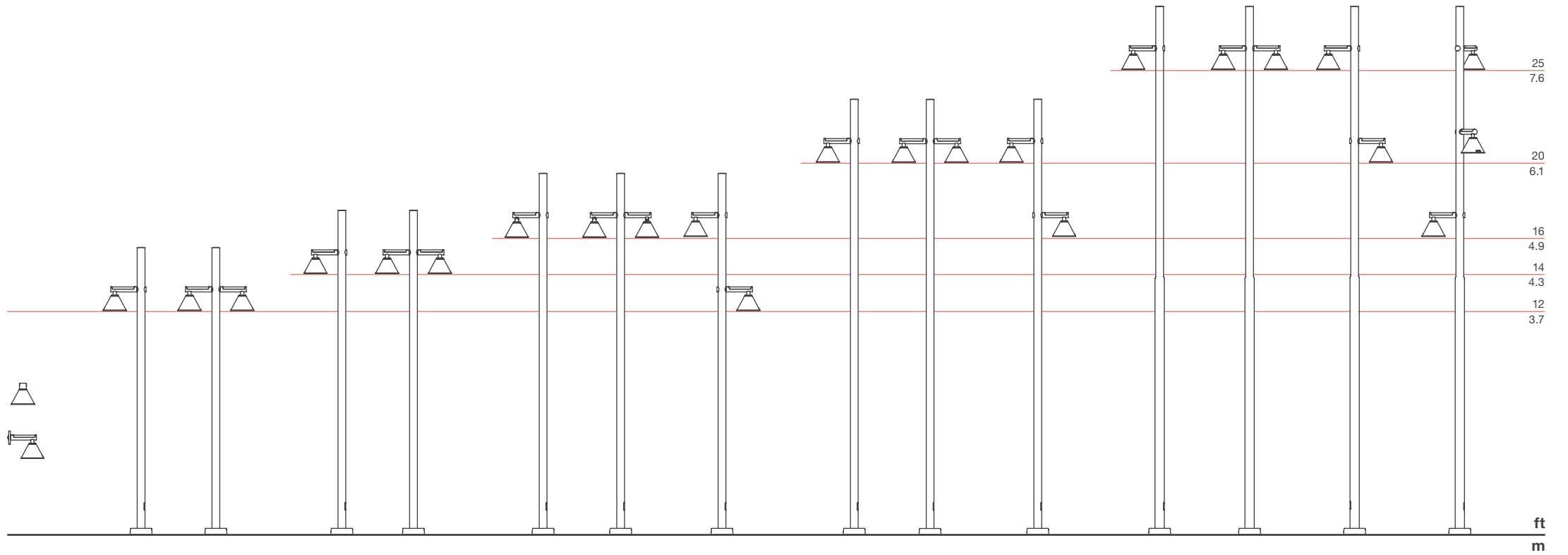

# Polar Plots

30 LED, Standard Output, Clear Lens, 12' Mounting Height

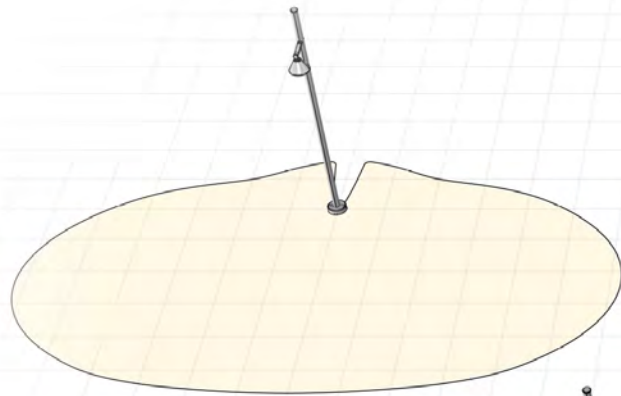

Type III

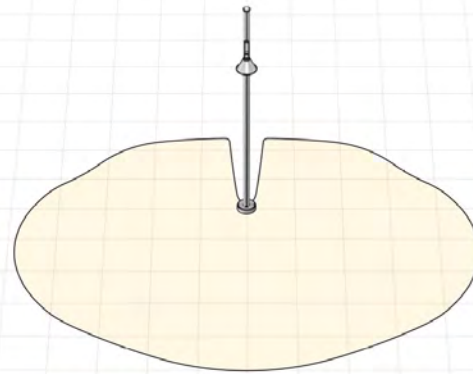

Type IV

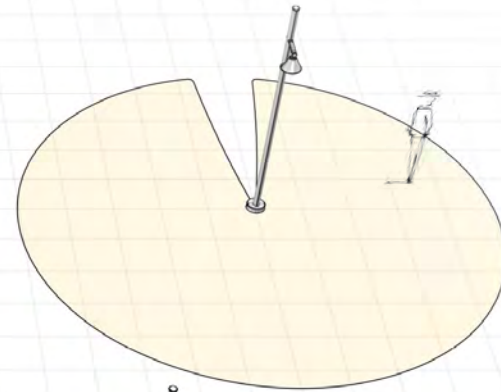

Type V

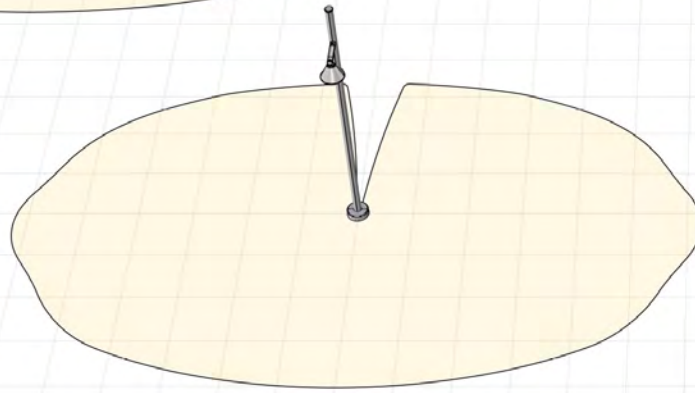

Type I

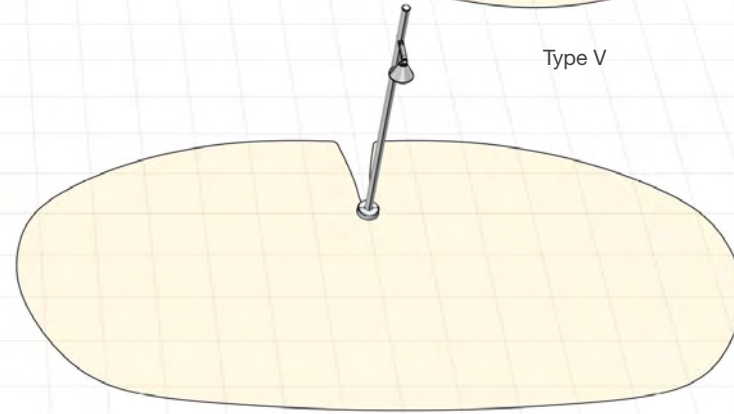

Type II

Plot lines represent 1.0fc, grid spacing is 3'

# Polar Plots

50 LED, Standard Output, Clear Lens, 16' Mounting Height

Type V

Type I

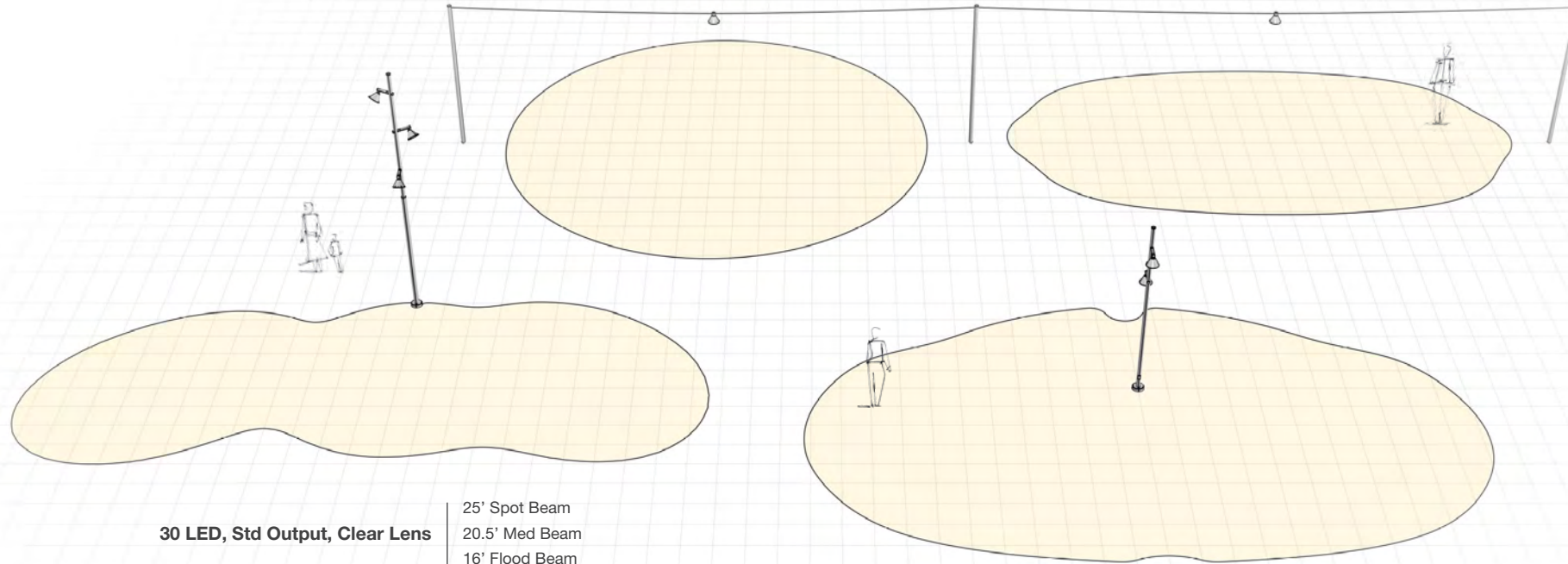

30 LED, Std Output, Clear Lens

- 25' Spot Beam
- 20.5' Med Beam
- 16' Flood Beam

30 LED, Std Output, Clear Lens

- 16', Type III
- 12', Type I

Plot lines represent 1.0fc, grid spacing is 3'



landscapeforms

**Moment**