



landscapeforms

Louis

Innovative, Adaptable, and Sustainable Urban Lighting

In partnership with the Barcelona-based design firm Urbidermis, Landscape Forms is pleased to announce the availability of Louis, the urban linear catenary luminaire. Inspired by the form-following-function rationalism that typified the work of architect Louis Kahn, Louis reflects fundamental design philosophies shared by Landscape Forms and Urbidermis—deeply rooted in adaptive versatility, sustainability, and an abiding respect for the urban environment.

A defining feature of Louis is the gentle arch of the luminaire's aluminum housing, softening the rectilinear form and shielding the catenary attachment points from view. The distinctive shape alludes to elemental geometries at the heart of modernist design. Unobtrusively suspended above pathways and passages, Louis offers practical illumination while enhancing the aesthetic appeal and emotional atmosphere of space.



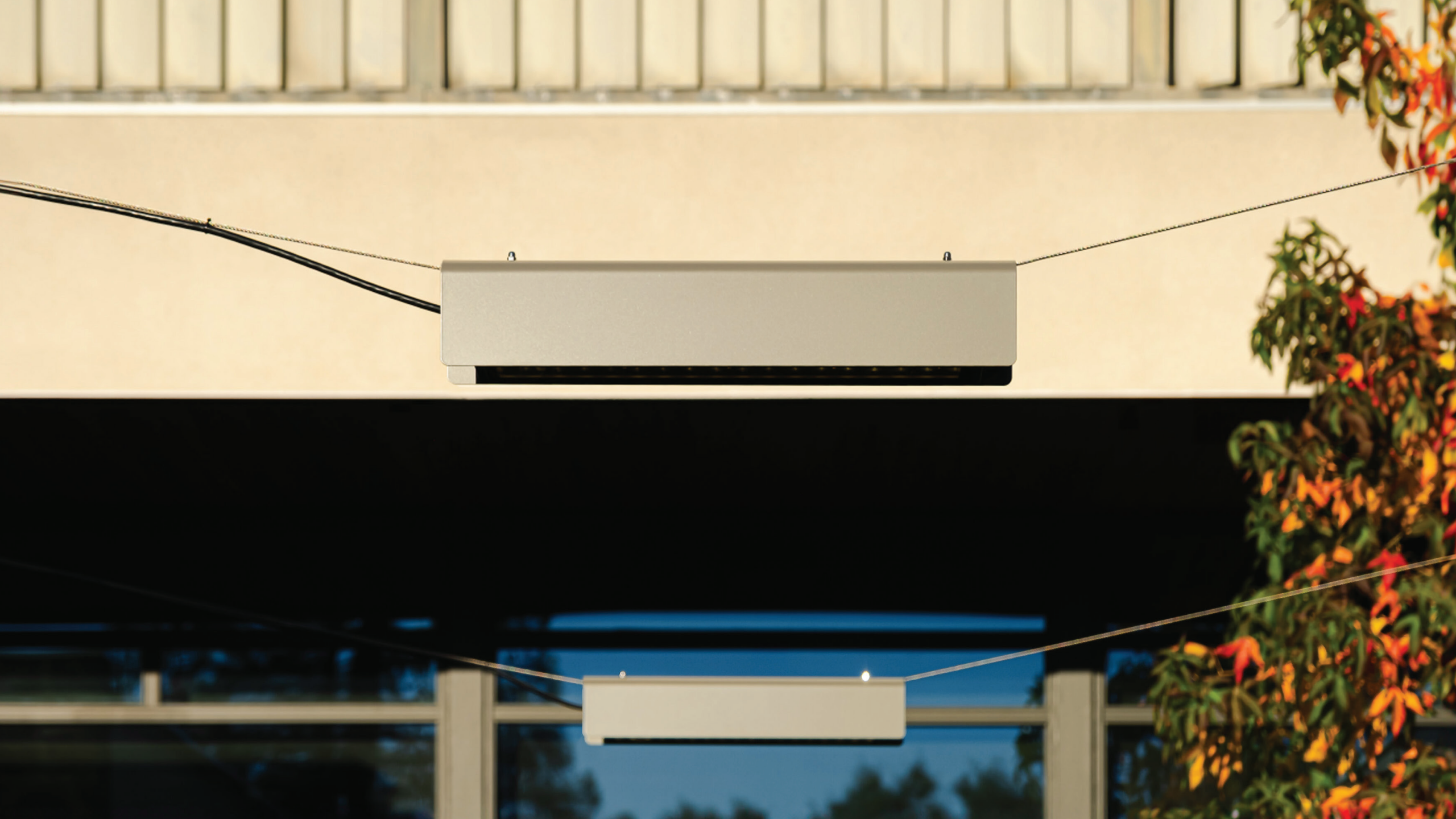



Lighting—Elevated

The elegant linear character of Louis is ideally suited to catenary applications and is a defining feature of its design. Suspended from cables that extend its horizontal line, Louis demonstrates its versatility by seamlessly integrating with diverse urban environments, from verdant parks to narrow passageways.

In what designers call “slow-velocity spaces” such as urban plazas and recreation areas, Louis catenary installations establish purposeful unobstructed boundaries of light. The comfortable, task-enabling illumination of Louis invites maximized utility of the outdoors, creating space for shared public activities—reading, eating, socializing, game-playing—prized by city dwellers everywhere.

The suspended linear profile of Louis works particularly well in sequence, making it an ideal solution for way-finding guidance. Suspended over pedestrian thoroughfares in regular cadence, Louis lights the way forward, providing a predictability and distanced perspective that helps to define and refine space, elevating while illuminating.

Constructed of high grade, anodized aluminum with powder-coated finish, providing long-lasting protection against humidity, pollution, and extreme temperatures.

Tempered optical glass diffuser with silicone sealing gaskets





Designed to Inspire

Louis is named for and draws inspiration from the architectural approaches and principles popularized by Louis Kahn. His ideas on the beauty that arose from the marriage of simplicity and functionality revolutionized modern architecture, and reframed how the intersection of space, light, and standard geometries defined complex urban structures and the elements within them.

Louis is available in a 26" and 48" length and a variety of finishes to meet any project's demands. The design ensures illumination is directed downward and is full cutoff. Crafted with grace and precision, Louis generates controlled pools of light to create suspended, free-flowing compositions in green spaces, pedestrian areas, city byways and open-air plazas, providing a new layer of order, beauty, and utility within the urban landscape.

26" and 48" lengths

2,000 – 8,000lm

Type V, II+II

2700K, 3000K, 4000K

Clear or diffused lens













A brighter way forward

Landscape Forms lighting solutions are designed with purpose. We believe in designing luminaires that enhance the experience of outdoor space. We take pride in the thoughtful integration of advanced technology coupled with high-performance materials and responsible manufacturing to ensure our solutions are effective, appropriate, and uniquely suited to the needs of the project and the landscape.

Guided by the principle of placemaking through design, Landscape Forms believes lighting should create an exceptional visual experience rather than overpower the night. We collaborate with architects and designers to shape public spaces that foster connection, enrich communities, and seamlessly blend functionality with aesthetics. This approach ensures we elevate the built environment while reinforcing our dedication to sustainability and design excellence.



Application Examples

Campus Plaza



Campus Plaza

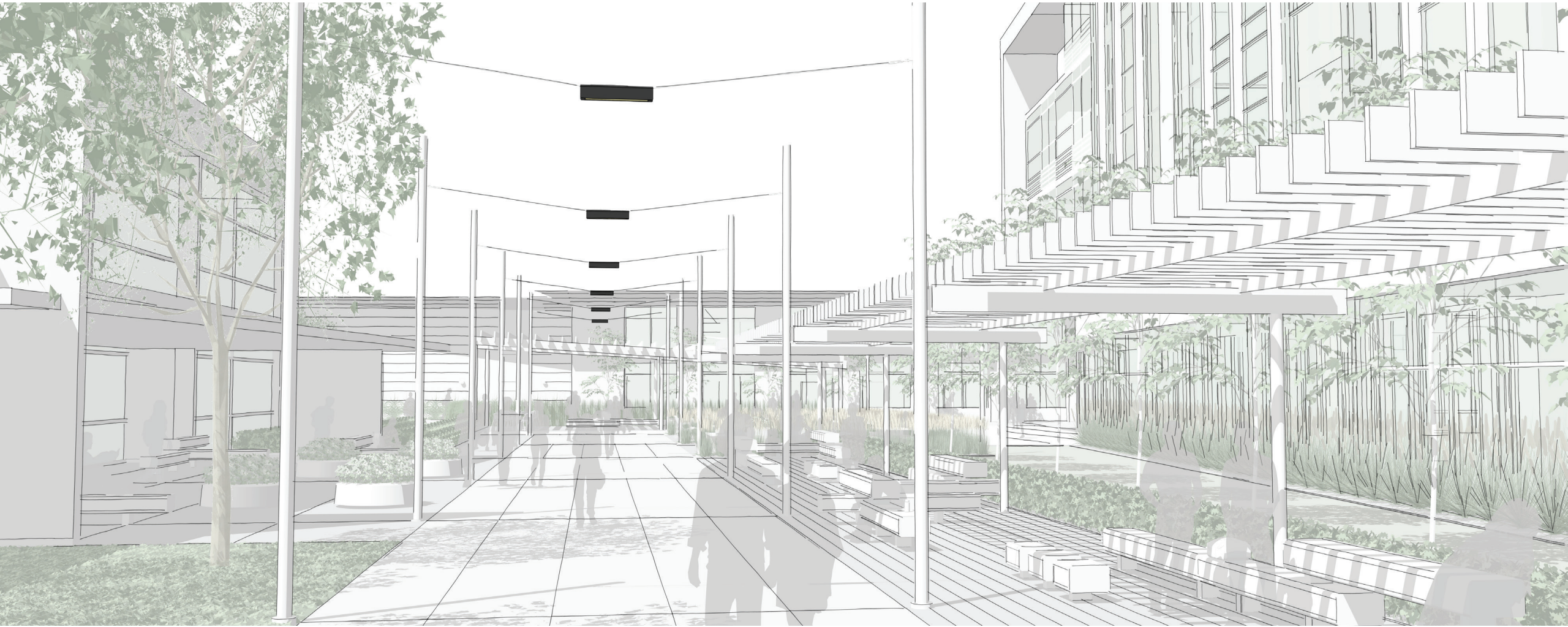

Campus Plaza

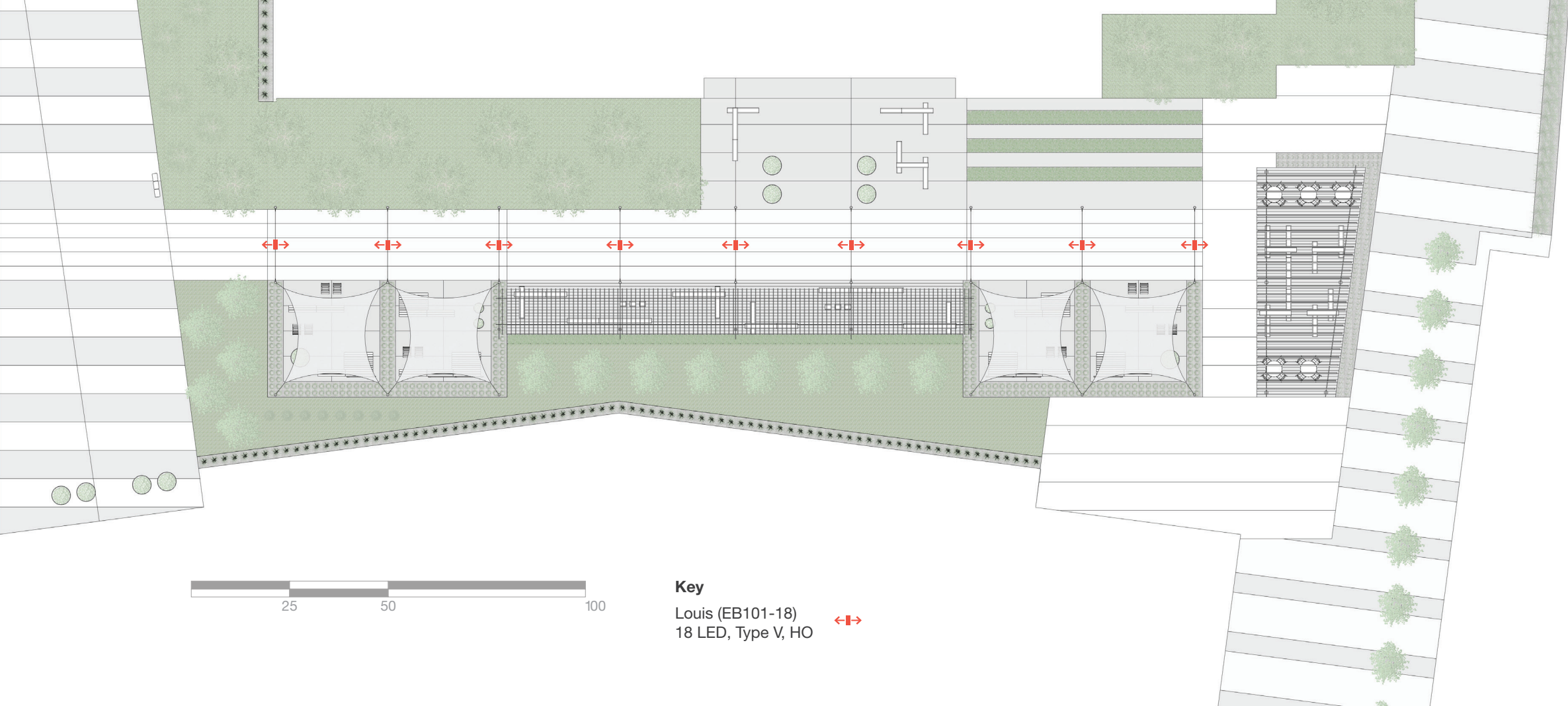

Key
Louis (EB101-18)
18 LED, Type V, HO 

Statement of Line

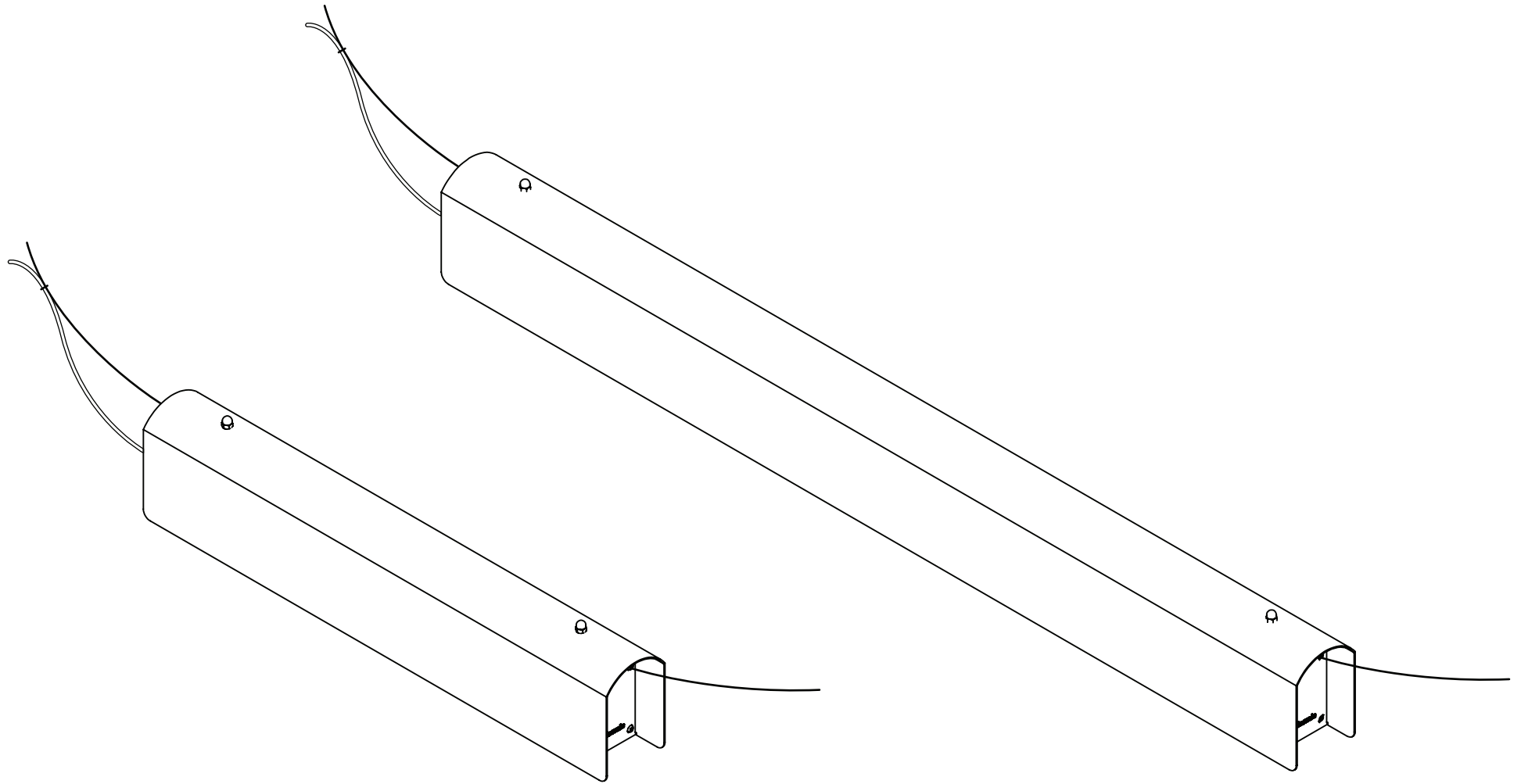

Polar Plots

36 LED, Standard Output, Clear Lens, 16' Lens Height

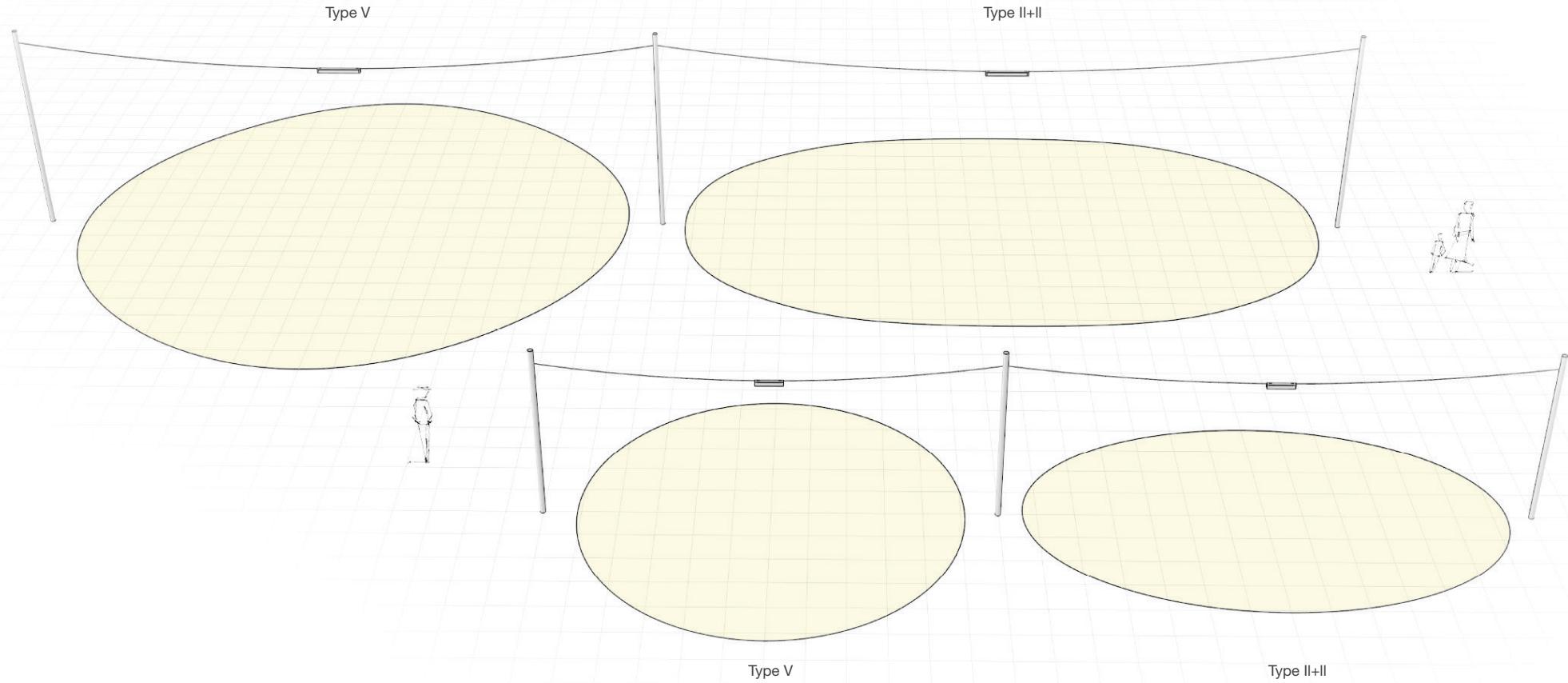

18 LED, Low Output, Clear Lens, 12' Lens Height

Plot lines represent 1.0fc, grid spacing is 3'

Materials

Powdercoated Metal

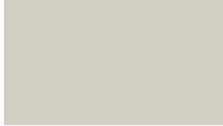

White
RAL 9002 (UWH)



Medium Grey
RAL 9007 (UMG)



About Our Partner

Louis was created to reflect four central pillars that inform the Urbidermis approach to design: adaptability to urban space; respect for living things; the positive potential of technological change; and responding to the challenges of a changing climate. Channeling these values into a design approach has resulted in products that are beautiful, environmentally conscious, and socially responsive and responsible—foundational hallmarks of all Urbidermis designs.

Urbidermis is B Corp certified, underlining its commitment to social and environmental performance, accountability, and transparency. B Corp certification means that Urbidermis has met exacting labor and human rights standards and achieved sustainability thresholds governing its supply chain and materials input.

Urbidermis

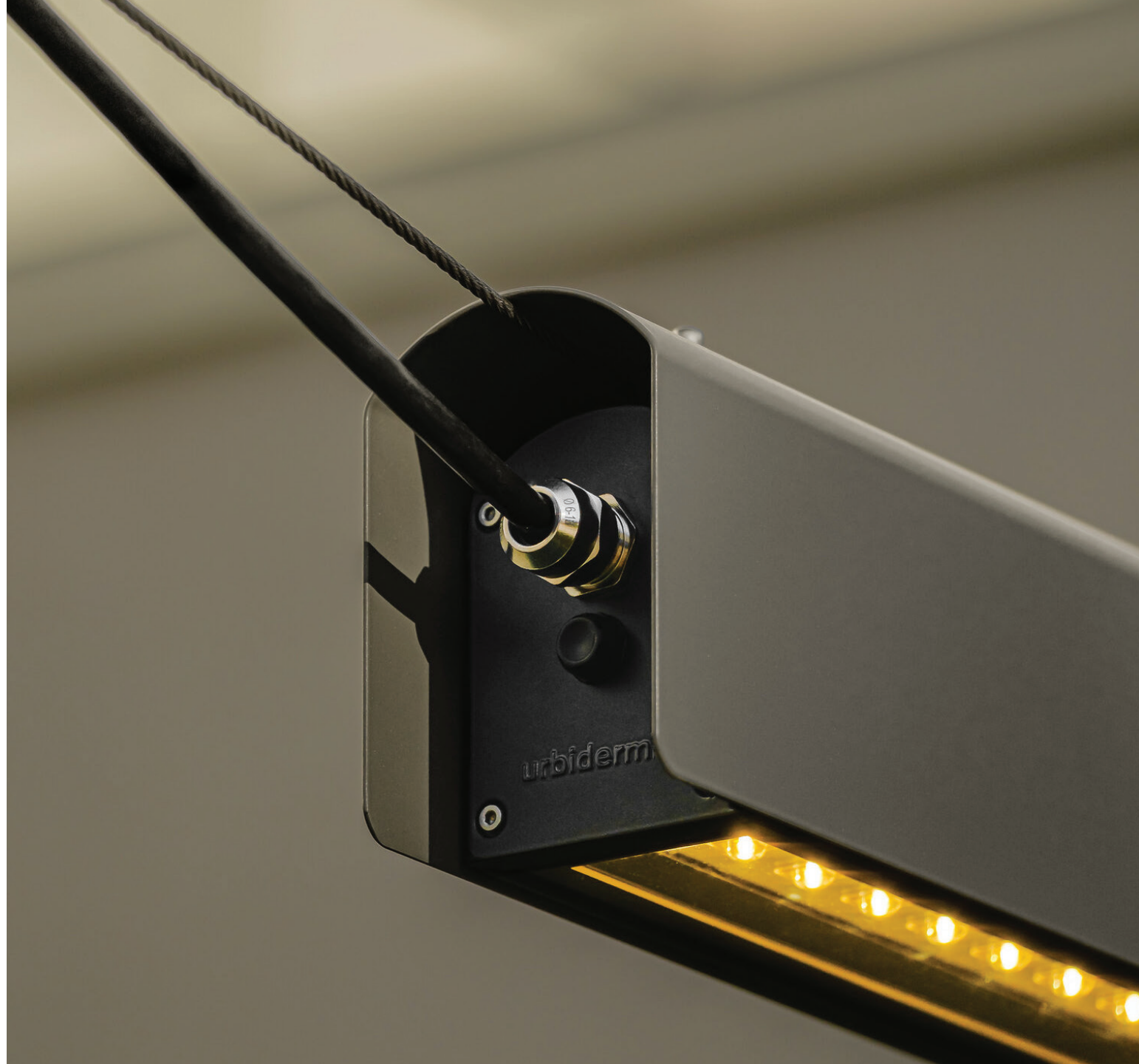

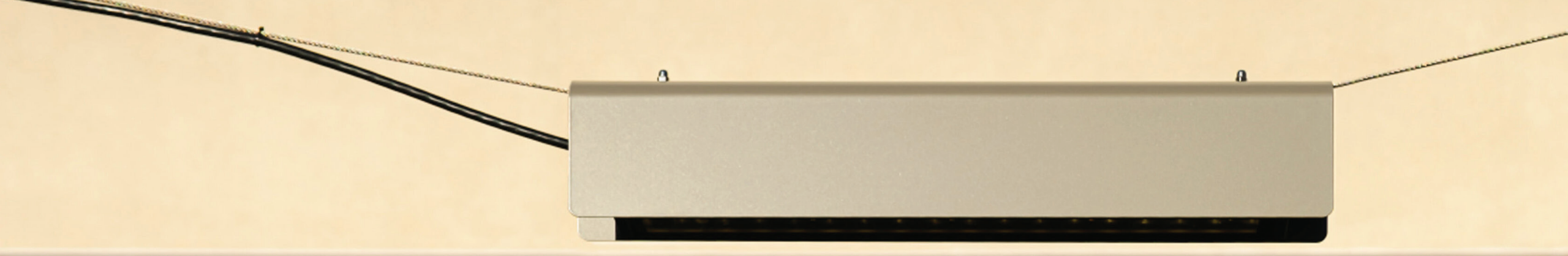

landscapeforms

Louis